

8 各部名稱 Description

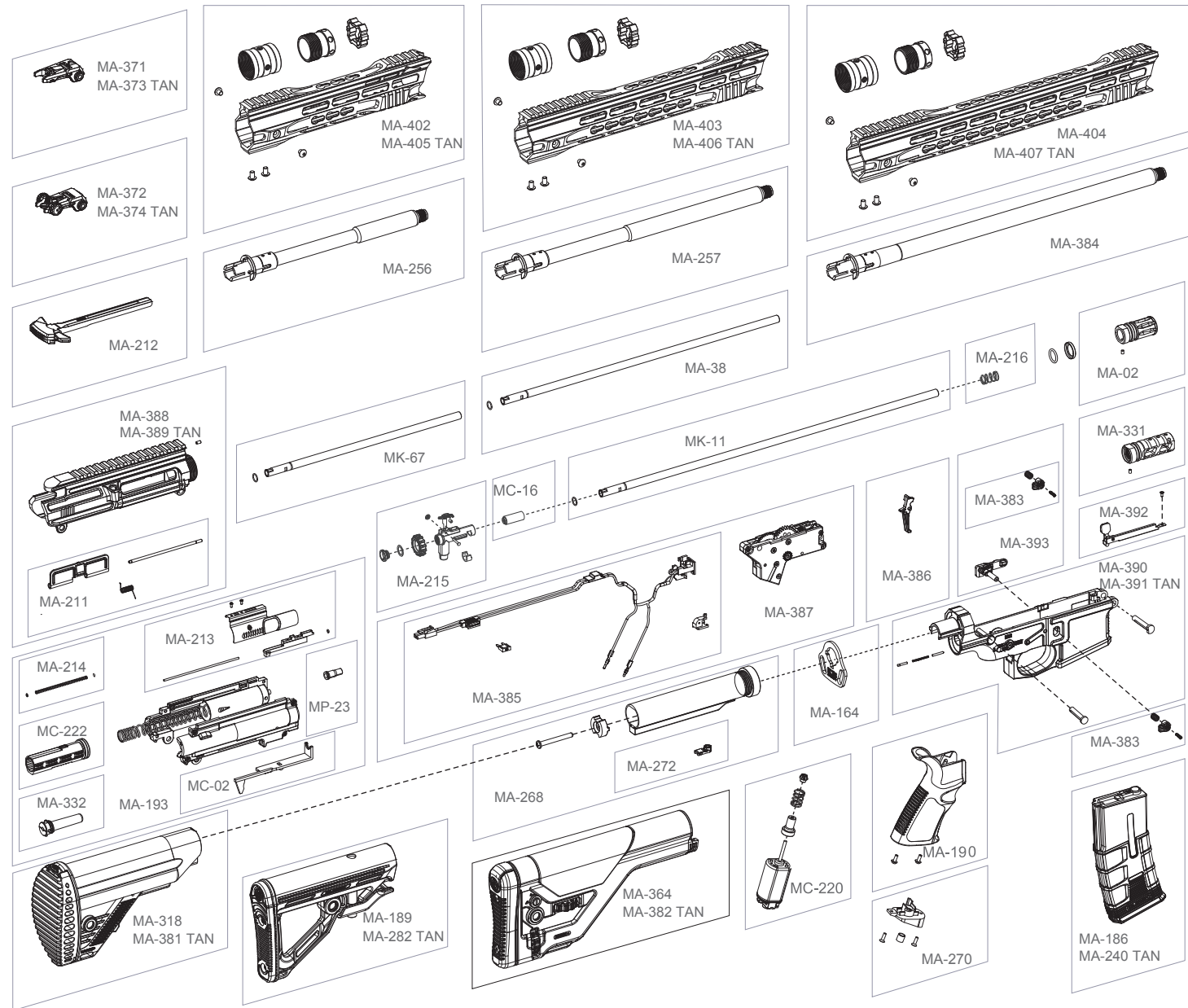

Patents acquired: US 7,077,117 B1 / US D706,879 S / US D706,880 S / R.O.C. M244431 / R.O.C. M320468 / R.O.C. D160112 / R.O.C. D159178 / R.O.C. M480664 / EM002246579-0001 / R.O.C.D168410 / R.O.C.D1531145 / USD744048S / EM002541334-0001 / R.O.C. D180133 / EM003297555-0001 / EM003297530-0001

WARNING 警告 電槍使用之注意事項 Maintenance

- 請勿使用回收及劣質的 BB 彈，以減少槍管損耗與避免卡彈的情形發生。
 - 如發現有卡彈的情形，應立即停止射擊，如卡彈後再勉強射擊，則會增加齒輪損耗。請使用內附通槍條，將卡彈清除後才可繼續使用。若完成通槍基本故障排除後仍無法使用時，請回原採購店家或專業經銷商尋求維修服務。
 - 使用前請先確定您的電池已充滿電，當使用中發覺電池即將用盡或射擊速度降低時，應立即更換電池。
 - 請定期使用通槍條清潔槍管，以保持槍支射擊時的準確性及減少卡彈的情形發生。
 - 請勿經常空槍射擊，以減少BOX及齒輪不必要的損耗。
- 使用前請務必詳閱此說明書限18歲以上使用
Always read through this manual before operation.
User restricted to 18 years of age or older.

內容如有任何更新，將以官方網站公布為準。
Latest updates will be announced on our official website.



WWW.ICSSBB.COM

1 各部名稱 Component name



■ CXP-MARS Komodo



■ CXP-MARS SBR



■ CXP-MARS Carbine



■ CXP-MARS DMR



*每一款槍型基本配備不同依實際出貨為主。圖片僅供參考。
The components/accessories for each model may have kind of differences depending on the actual goods. Images are only for reference.

2 彈匣使用方式 Magazine attachment

2-1 裝BB彈方式 Load BBs

將彈匣上蓋依箭頭方向推開再倒入BB彈。
Open the cover to load BBs.

建議使用ICS 6mm BB彈
ICS 6mm caliber BBs are recommended for optimum performance.

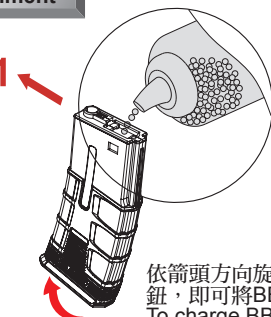

依箭頭方向旋緊彈匣底下旋鈕，即可將BB彈順利送出。
To charge BB feed spring, please rotate the gear under the magazine.

2-2 裝卸彈匣 Magazine Loading and Unloading

直接將彈匣插入槍身彈匣插槽；按下彈匣釋放鈕以卸除彈匣。
Directly insert magazine into magazine slot; unload the magazine by pressing the magazine catch button.

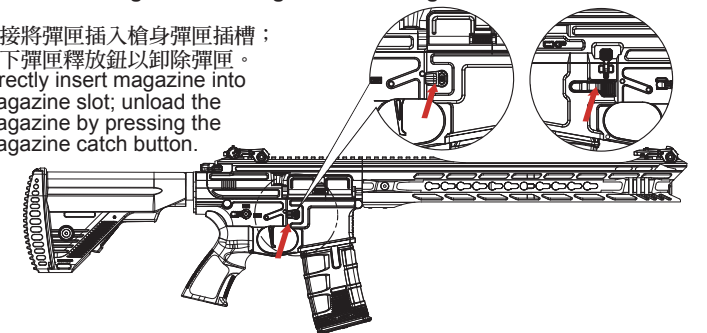

3 可動部的說明 Operation

3-1 可作動作 Movable parts

槍機拉柄
Charging handle
拉柄拉動可打開防塵蓋
Pull the charging handle to open the ejection cover

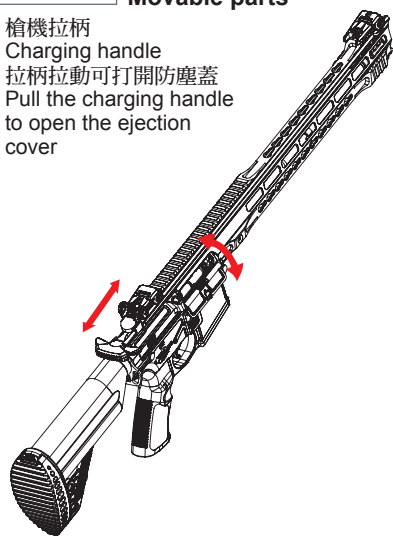

1. 槍枝使用完畢請轉至單發狀態下發射2~3下後再按止逆轉釋放鈕，可將活塞彈簧回覆至原處。
2. 槍身做分解時，必須先釋放活塞彈簧，才可做分解動作。
1. After playing, fire 2-3 in semi, then switch the fire selector to safety to release the spring tension before storage.
2. Before disassembling the gearbox, please make sure to switch the fire selector to safety to release the spring tension.

3-2 槍身結合3號齒正確位置圖 The Correct Position of Sector Gear

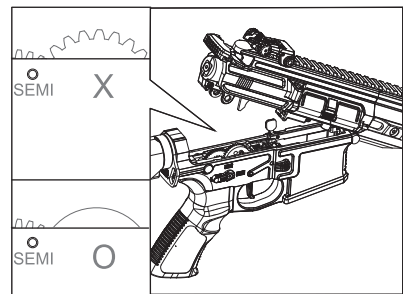

3號齒在槍身結合時，必須轉到正確位置，才可將上槍身蓋下。
Make sure sector gear is turned to the correct position before reassembling the receiver/gearbox.

3-4 馬達間隙調整 Motor Gap Adjustment

使用4mm六角扳手來進行馬達齒間隙調整(出廠前已調整好)。
Use the 4mm Allen key to make the fine-tune adjustment when needed.
(Adjust when needed. Already made before out of factory)

3-3 調整伸縮托長度 Adjust Retractable Stock Length

注意：依所選購的Li-Po電池大小，將托桿膠塊安裝於A或B，以免托桿作動時損傷電池。
Attention: According to the Li-Po battery size, install the rubber block into position A or B to avoid damaging battery during adjusting retractable stock.

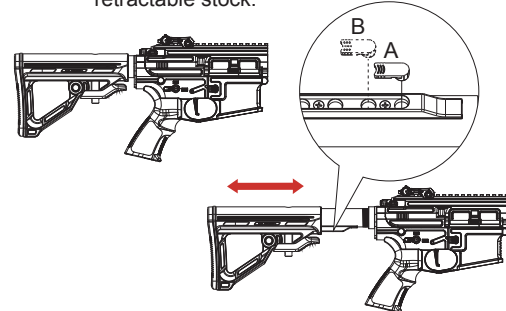

按下卡榫，即可將伸縮托向後拉或向前推，共有4~5段可供調整長度。
Press and hold the stock release lever to unlock. Adjust the 4~5 position retractable stock to the most comfortable position.

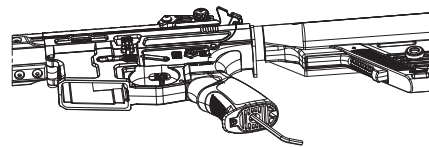

4 調整視孔準星 Sights Adjustment

4-1 準星高度調整 Front Sight Adjustment

將準星調整桿壓入定位轉動即調整高低
Rotate the front side pin to adjust the front sight by sight tool.

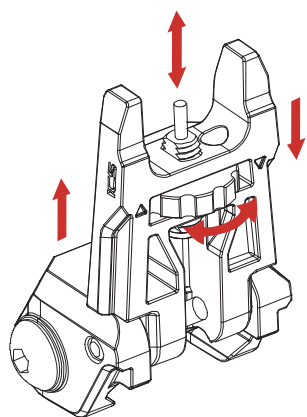

4-2 視孔風偏調整 Rear Sight Adjustment

依旋鈕方向旋轉，則可將視孔左、右調整
Rotate clockwise to aim right
Rotate counter-clockwise to aim left

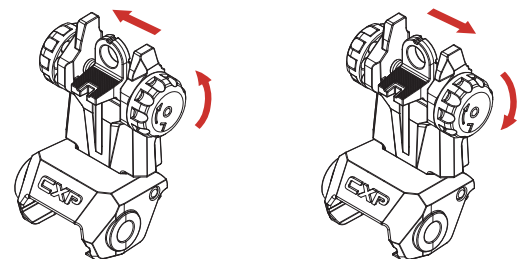

4-3 CFS折疊式準星/CFS折疊式照門 CFS Front Folding Sight / CFS Rear Folding Sight

向上推準星即可豎直準星座
向後推準星座即可收合準星座
Flip up the front sight.
Press down the front sight to store.

向上推視孔桿即可豎直視孔
向後推視孔桿即可收合視孔
Flip up the rear sight.
Press down the rear sight to store.

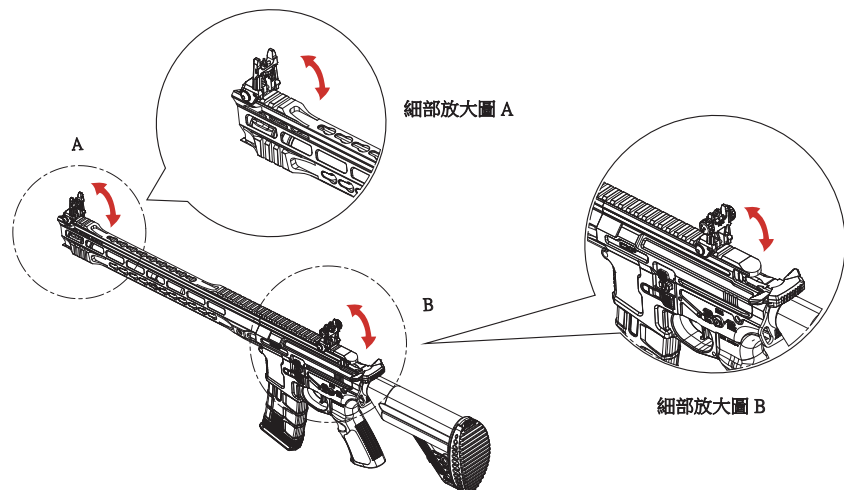

4-4 選擇射擊模式 Shooting Mode Setting

保險 Safety 單發 Semi 連發 Full Auto



Switch the selector lever to safety position (aim forward) can release the spring and cease fire synchronously.
1. 槍枝使用完畢轉至單發狀態下發射2~3下後再關保險，可將活塞彈簧回覆至原處。
2. 槍身做分解時，必須先釋放活塞彈簧，才可做分解動作。
1. After playing, fire 2-3 by using semi automatic, then switch the selector lever to safety position to release the spring tension before storage.
2. Before disassembling the gear box, always release the spring by turning selector lever to safety position.

5 H-UP 彈道調整 H-UP adjustment

1. 調整撥盤向上使子彈下降
1. Rotate the dial counter-clockwise to make the pellet go down.
2. 調整撥盤向下使子彈上升
2. Rotate the dial clockwise to make the pellet go up.

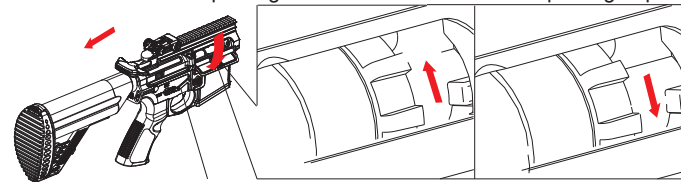

防塵蓋
Port cover
將槍機拉柄往後拉，防塵蓋即可打開。
Pull the charging handle backward to open the ejection cover for H-UP adjustment.

H-UP調整：
子彈過於上飄，請調整撥盤向上旋轉。子彈過於下墜，請調整撥盤向下旋轉。BB彈呈現一直線的彈道才是正確射法。

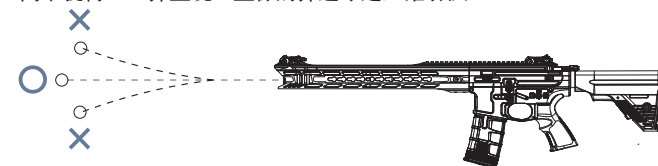

H-UP Adjustment:
When the BB pellet rises up, rotate the dial counter-clockwise to lower trajectory down. When the BB pellet falls down, rotate the dial clockwise to raise the trajectory up. Make sure the trajectory of BB pellet to be straight.

6 電池及護木的拆裝方法 Batteries and handguard installation

注意 CAUTION ※重新組裝時，必須依反向動作組合
Reassembling is the reverse of disassembling procedures.

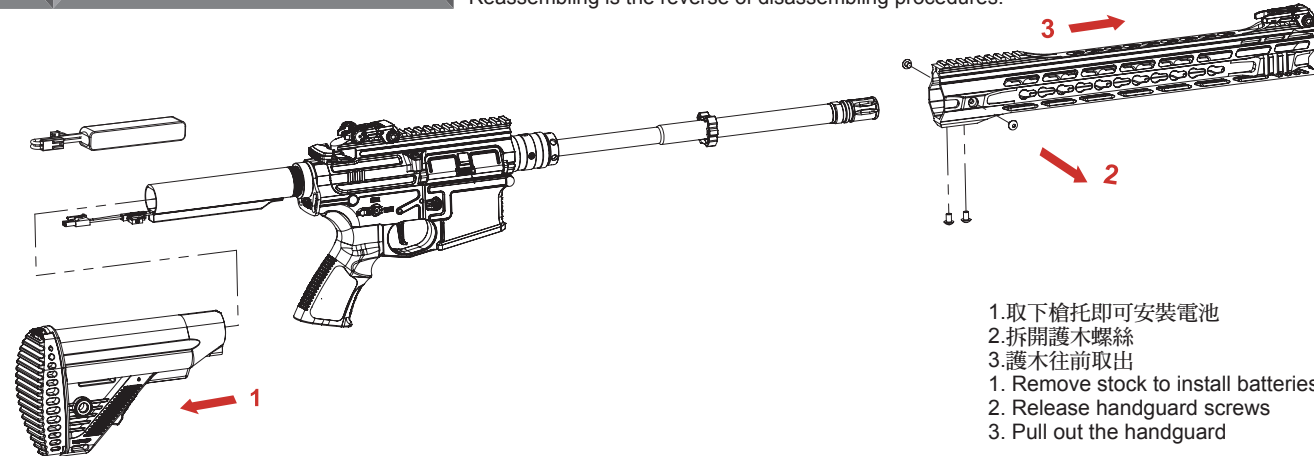

1. 取下槍托即可安裝電池
2. 拆開護木螺絲
3. 護木往前取出
1. Remove stock to install batteries
2. Release handguard screws
3. Pull out the handguard

7 齒輪箱拆解 Disassemble Gearbox

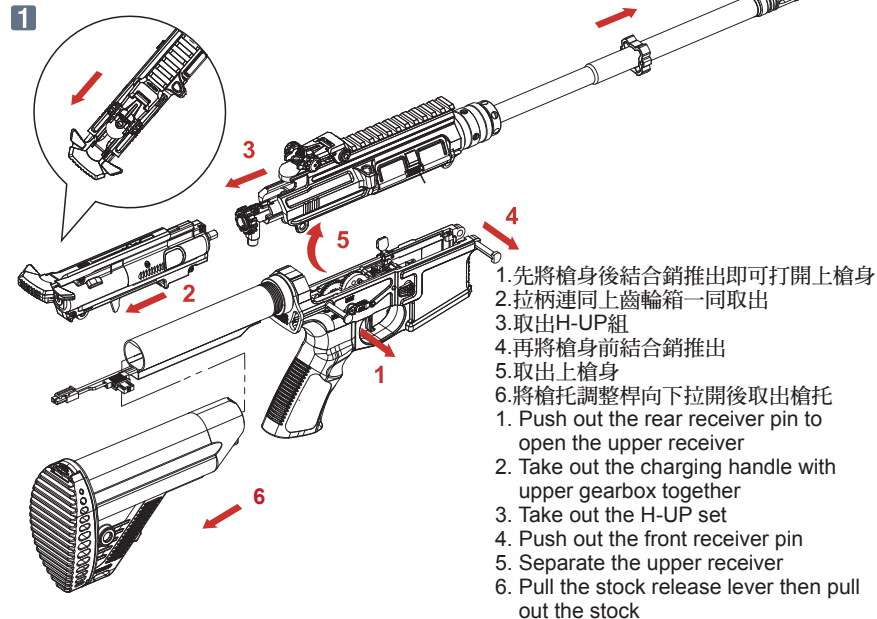

1. 先將槍身後結合銷推出即可打開上槍身
2. 拉柄連同齒輪箱一同取出
3. 取出H-UP組
4. 再將槍身前結合銷推出
5. 取出上槍身
6. 將槍托調整桿向下拉開後取出槍托
1. Push out the rear receiver pin to open the upper receiver
2. Take out the charging handle with upper gearbox together
3. Take out the H-UP set
4. Push out the front receiver pin
5. Separate the upper receiver
6. Pull the stock release lever then pull out the stock

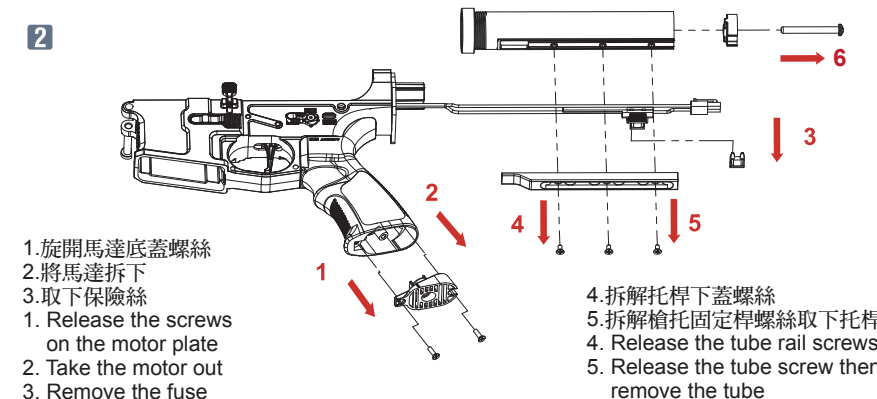

1. 旋開馬達底蓋螺絲
2. 將馬達拆下
3. 取下保險絲
4. 拆解托桿下蓋螺絲
5. 拆解槍托固定桿螺絲取下托桿
1. Release the screws on the motor plate
2. Take the motor out
3. Remove the fuse
4. Release the tube rail screws
5. Release the tube screw then remove the tube

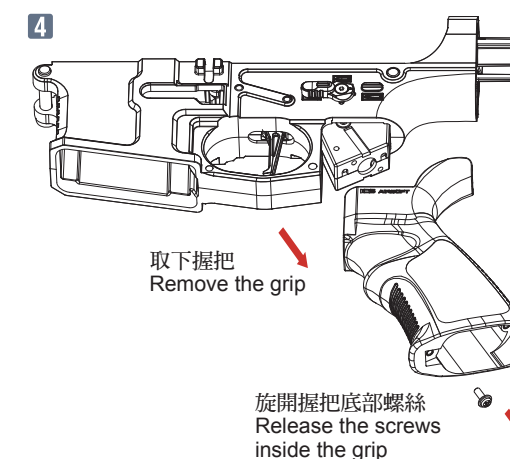

1. 取下握把
Remove the grip
2. 旋開握把底部螺絲
Release the screws inside the grip

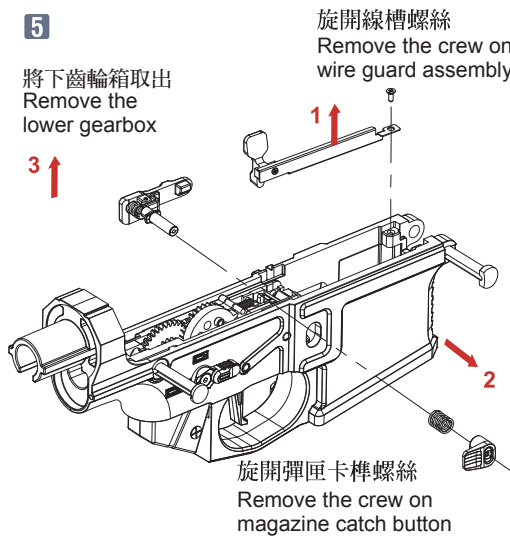

1. 將下齒輪箱取出
Remove the lower gearbox
2. 旋開線槽螺絲
Remove the crew on wire guard assembly
3. 旋開彈匣卡榫螺絲
Remove the crew on magazine catch button