

CNC ALUMINUM HOPUP CHAMBER M4i - PRO

MAXX MODEL PRODUCTS, INC.

COPYRIGHT © 2022

1 INNER BARREL INSTALLATION

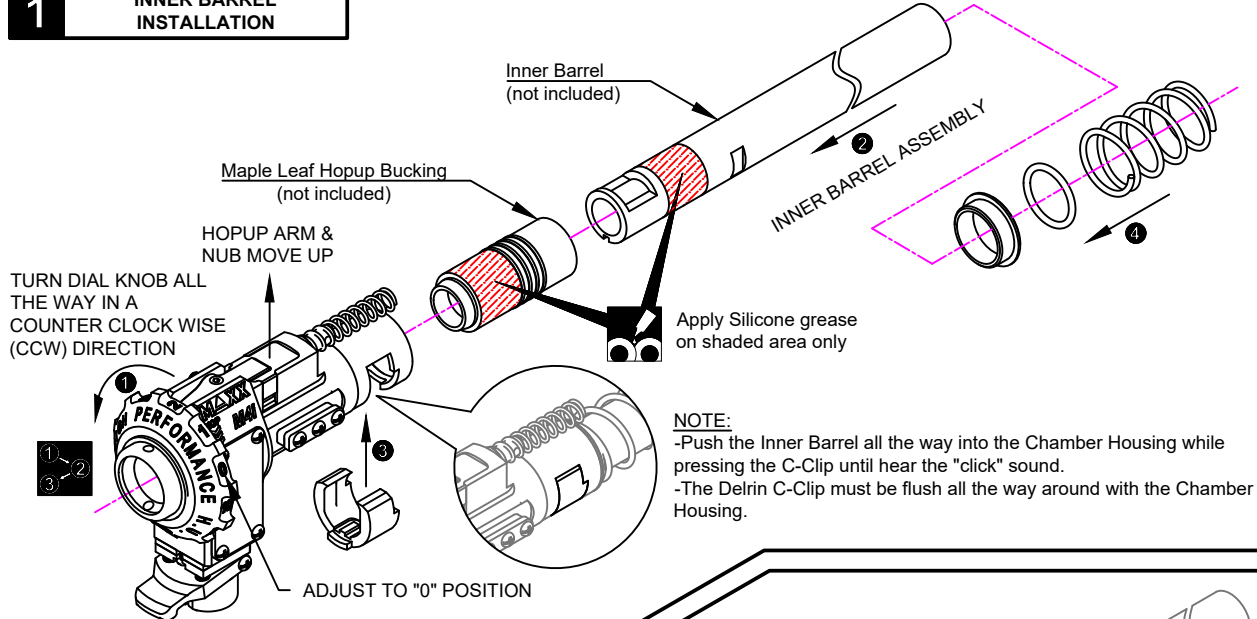

2 HOPUP ARM & INLET ADAPTOR INSTALLATION

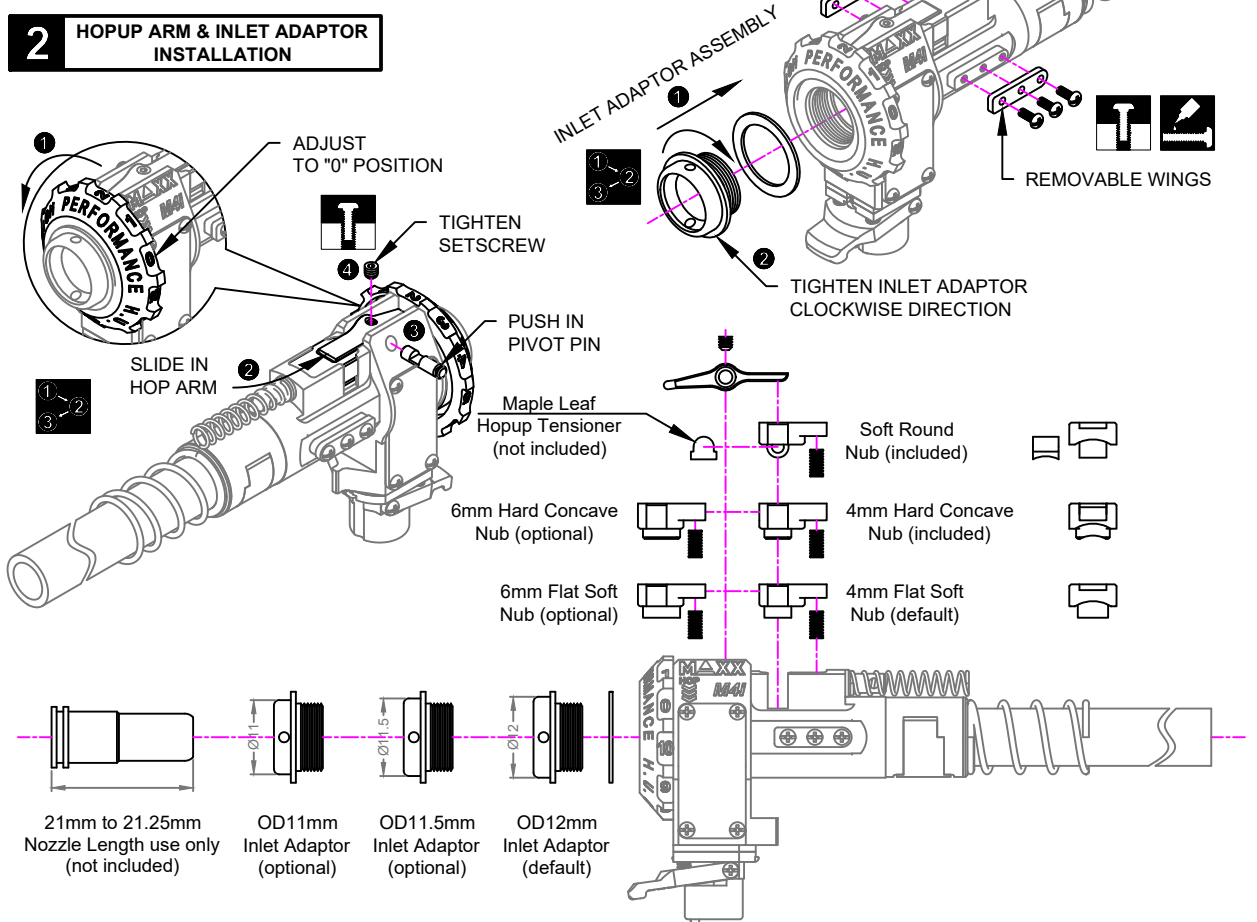

- Assemble in this order
- Apply Silicone grease
- Apply Threadlocker
- Tighten firmly, do not overtighten

CAUTION: Please check your model carefully before operation!

REV. MX-HOP010MI-190522-01